



## Bus Operating Conditions

### • General

| Parameter                 | Symbol | Min. | Max.         | Unit          | Remark |
|---------------------------|--------|------|--------------|---------------|--------|
| Peak voltage on all lines |        | -0.3 | $V_{DD}+0.3$ | V             |        |
| All Inputs                |        |      |              |               |        |
| Input Leakage Current     |        | -10  | 10           | $\mu\text{A}$ |        |
| All Outputs               |        |      |              |               |        |
| Output Leakage Current    |        | -10  | 10           | $\mu\text{A}$ |        |

### • Power Supply Voltage

| Parameter           | Symbol   | Min.             | Max.             | Unit | Remark                               |
|---------------------|----------|------------------|------------------|------|--------------------------------------|
| Supply voltage      | $V_{DD}$ | 2.7              | 3.6              | V    |                                      |
| Output High Voltage | $V_{OH}$ | $0.75 * V_{DD}$  |                  | V    | $I_{OH}=-100\mu\text{A}@V_{DD}$ Min. |
| Output Low Voltage  | $V_{OL}$ |                  | $0.125 * V_{DD}$ | V    | $I_{OL}=100\mu\text{A}@V_{DD}$ Min.  |
| Input High Voltage  | $V_{IH}$ | $0.625 * V_{DD}$ | $V_{DD}+0.3$     | V    |                                      |
| Input Low Voltage   | $V_{IL}$ | $V_{SS}-0.3$     | $0.25 * V_{DD}$  | V    |                                      |
| Power up time       |          |                  | 250              | ms   | From 0v to $V_{DD}$ Min.             |

### • Current Consumption

The current consumption is measured by averaging over 1 second.

- Before first command: Maximum 15 mA
- During initialization: Maximum 100 mA
- Operation in Default Mode: Maximum 100 mA
- Operation in High Speed Mode: Maximum 200 mA
- Operation with other functions: Maximum 500 mA.

## Reliability and Durability

|                               |  |
|-------------------------------|--|
| <b>Temperature</b>            | Operation: -25 °C / 85 °C<br>Storage: -40 °C (168h) / 85 °C (500h)<br>Junction temperature: max. 95 °C                                     |
| <b>Moisture and corrosion</b> | Operation: 25 °C / 95% rel. humidity<br>Storage: 40 °C / 93% rel. hum./500h<br>Salt Water Spray: 3% NaCl/35C; 24h acc. MIL STD Method 1009 |
| <b>Durability</b>             | 10.000 mating cycles;  |
| <b>Bending</b>                | 10N  |
| <b>Torque</b>                 | 0.15N.m or +/-2.5 deg  |
| <b>Drop test</b>              | 1.5m free fall   |
| <b>Visual inspection</b>      | No warp page; no mold skin; complete form; no cavities surface smoothness <=   |
| <b>Shape and form</b>         | -0.1 mm/cm <sup>2</sup> within contour; no cracks; no pollution (fat, oil dust, etc.)  |

## • CID Register

The Card IDentification (CID) register is 128 bits wide. It contains the card identification information used during the card identification phase. Every individual flash card shall have a unique identification number. The structure of the CID register is defined in the following paragraphs:

| Name                  | Field | Width | CID-slice |
|-----------------------|-------|-------|-----------|
| Manufacturer ID       | MID   | 8     | [127:120] |
| OEM/Application ID    | OID   | 16    | [119:104] |
| Product name          | PNM   | 40    | [103:64]  |
| Product revision      | PRV   | 8     | [63:56]   |
| Product serial number | PSN   | 32    | [55:24]   |
| reserved              | --    | 4     | [23:20]   |
| Manufacturing date    | MDT   | 12    | [19:8]    |
| CRC7 checksum         | CRC   | 7     | [7:1]     |
| not used, always 'f'  | -     | 1     | [0:0]     |

## • MID

An 8-bit binary number that identifies the card manufacturer. The MID number is controlled, defined, and allocated to a SD Memory Card manufacturer by the SD-3C, LLC. This procedure is established to ensure uniqueness of the CID register.

## • OID

A 2-character ASCII string that identifies the card OEM and/or the card contents (when used as a distribution media either on ROM or FLASH cards). The OID number is controlled, defined, and allocated to a SD Memory Card manufacturer by the SD-3C, LLC. This procedure is established to ensure uniqueness of the CID register.

Note:

SD-3C, LLC licenses companies that wish to manufacture and/or sell SD Memory Cards, including but not limited to flash memory, ROM, OTP, RAM, and SDIO Combo Cards.

SD-3C, LLC is a limited liability company established by Matsushita Electric Industrial Co. Ltd., SanDisk Corporation and Toshiba Corporation.

## • PNM

The product name is a string, 5 ASCII characters long.

## • PRV

The product revision is composed of two Binary Coded Decimal (BCD) digits, four bits each, representing an “n.m” revision number. The “n” is the most significant nibble and “m” is the least significant nibble.

As an example, the PRV binary value field for product revision “6.2” will be: 0110 0010

## • PSN

The Serial Number is 32 bits of binary number.

## • MDT

The manufacturing date composed of two hexadecimal digits, one is 8 bit representing the year(y) and the other is four bits representing the month(m).

The “m” field [11:8] is the month code. 1 = January.

The “y” field [19:12] is the year code. 0 = 2000.

As an example, the binary value of the Date field for production date “April 2001” will be:

00000001 0100.

## • CRC

CRC7 checksum (7 bits).

## Mechanical Dimension

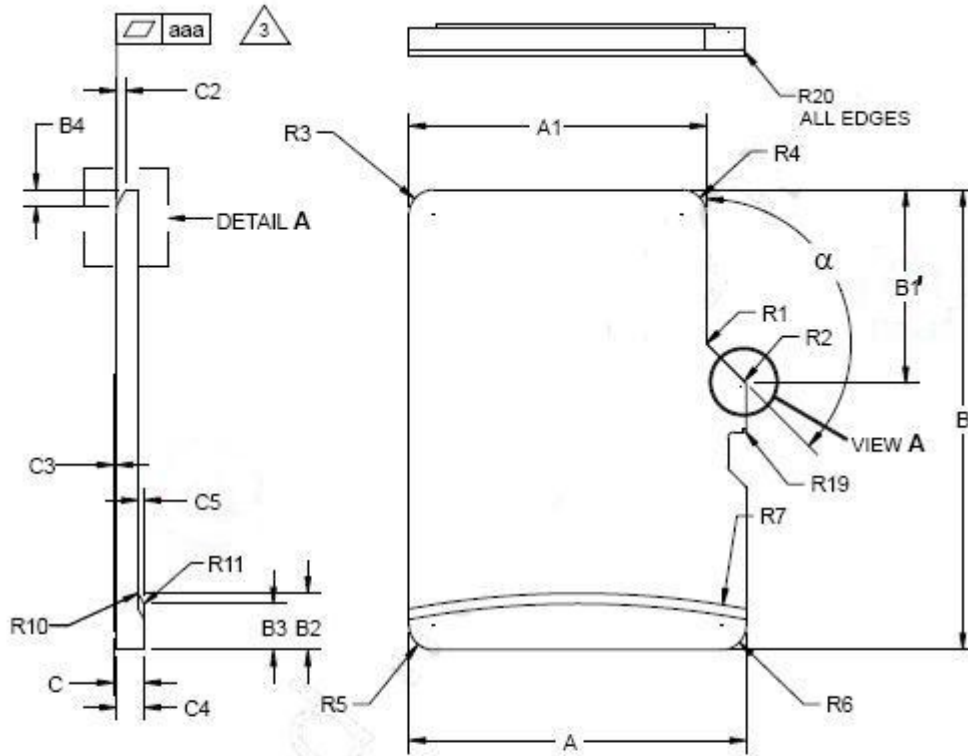

## Mechanical Form Factor

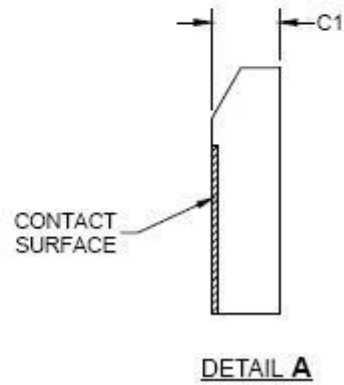
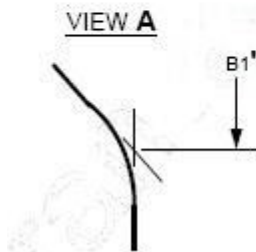

## Mechanical Description: Top View

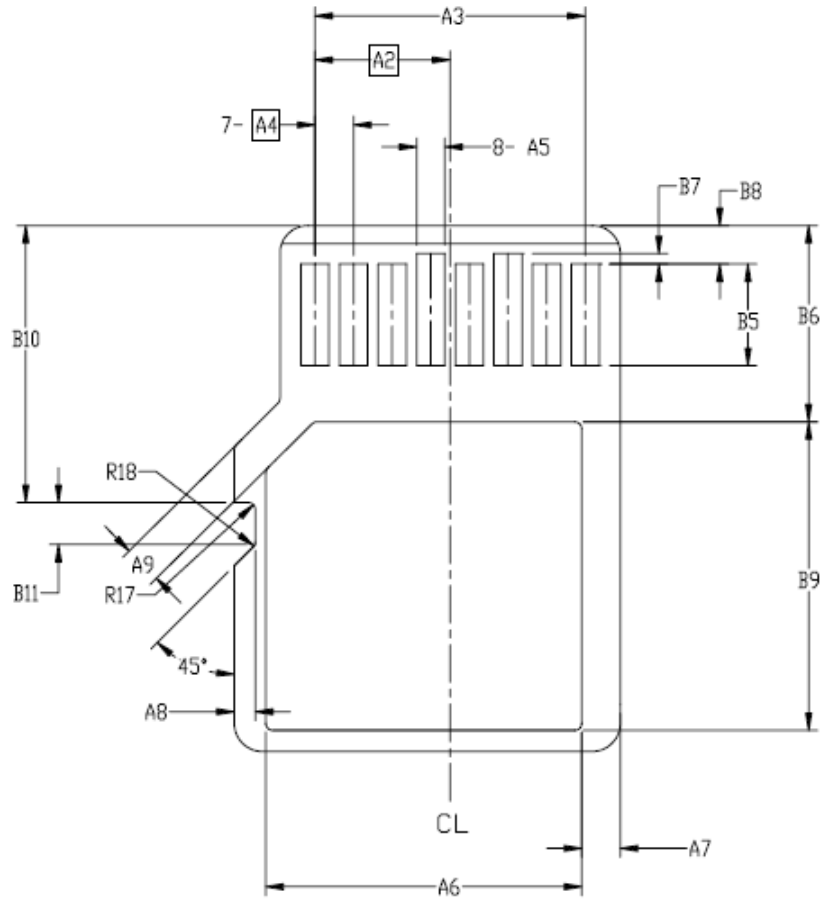

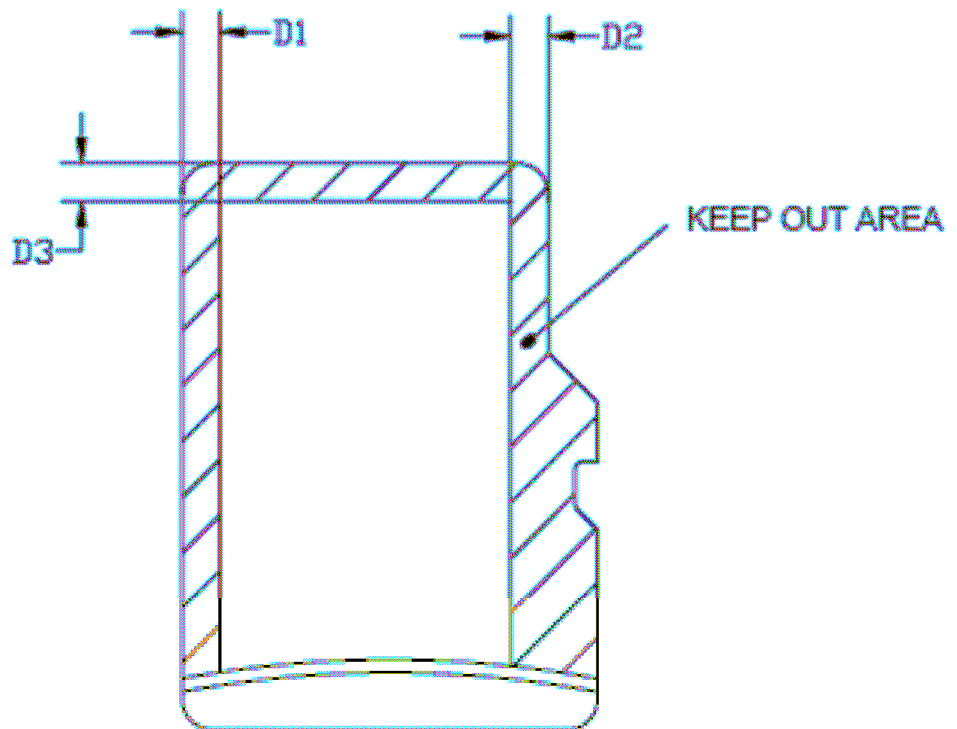

***Mechanical Description: Bottom View***



***Mechanical Description: Keep Out Area***

| SYMBOL | COMMON DIMENSION  |       |       | NOTE  |
|--------|---|-------|-------|-------|
|        | MIN   | NOM   | MAX   |       |
| A      | 10.90   | 11.00 | 11.10 |       |
| A1     | 9.60  | 9.70  | 9.80  |       |
| A2     | -   | 3.85  | -     | BASIC |
| A3     | 7.60  | 7.70  | 7.80  |       |
| A4     | -   | 1.10  | -     | BASIC |
| A5     | 0.75  | 0.80  | 0.85  |       |
| A6     | -   | -     | 8.50  |       |
| A7     | 0.90  | -     | -     |       |
| A8     | 0.60  | 0.70  | 0.80  |       |
| A9     | 0.80  | -     | -     |       |
| A10    | 1.35  | 1.40  | 1.45  |       |
| A11    | 6.50  | 6.60  | 6.70  |       |
| A12    | 0.50  | 0.55  | 0.60  |       |
| A13    | 0.40  | 0.45  | 0.50  |       |
| B      | 14.90   | 15.00 | 15.10 |       |
| B1'    | 6.13  | 6.23  | 6.33  |       |
| B2     | 1.64  | 1.84  | 2.04  |       |
| B3     | 1.30  | 1.50  | 1.70  |       |
| B4     | 0.42  | 0.52  | 0.62  |       |
| B5     | 2.80  | 2.90  | 3.00  |       |
| B6     | 5.50  | -     | -     |       |
| B7     | 0.20  | 0.30  | 0.40  |       |
| B8     | 1.00  | 1.10  | 1.20  |       |
| B9     | -   | -     | 9.00  |       |
| B10    | 7.80  | 7.90  | 8.00  |       |
| B11    | 1.10  | 1.20  | 1.30  |       |
| B12    | 3.60  | 3.70  | 3.80  |       |
| B13    | 2.80  | 2.90  | 3.00  |       |
| B14    | 8.20  | -     | -     |       |
| B15    | -   | -     | 6.20  |       |
| C      | -   | 1.00  | 1.10  |       |
| C1     | 0.60  | 0.70  | 0.80  |       |
| C2     | 0.20  | 0.30  | 0.40  |       |
| C3     | 0.00  | -     | 0.15  |       |
| C4     | 0.80  | -     | 1.10  |       |
| C5     | 0.15  | -     | -     |       |
| D1     | 1.00  | -     | -     |       |
| D2     | 1.00  | -     | -     |       |
| D3     | 1.00  | -     | -     |       |
| R1     | 0.20  | 0.40  | 0.60  |       |
| R2     | 0.20  | 0.40  | 0.60  |       |
| R3     | 0.70  | 0.80  | 0.90  |       |
| R4     | 0.70  | 0.80  | 0.90  |       |
| R5     | 0.60  | 0.80  | 0.90  |       |
| R6     | 0.60  | 0.80  | 0.90  |       |
| R7     | 29.50   | 30.00 | 30.50 |       |
| R10    | -   | 0.20  | -     |       |
| R11    | -   | 0.20  | -     |       |
| R17    | 0.10  | 0.20  | 0.30  |       |
| R18    | 0.20  | 0.40  | 0.60  |       |
| R19    | 0.05  | -     | 0.20  |       |
| R20    |  | -     | 0.15  |       |
| α      | 133°  | 135°  | 137°  |       |
| aaa    | -   | -     | 0.10  |       |

**Notes:**

1. DIMENSIONS AND TOLERANCING PER ASME Y14.5M-1994.
2. DIMENSIONS ARE IN MILLIMETERS.
-  3. COPLANARITY IS ADDITIVE TO C1 MAX THICKNESS.
-  4. ALL EDGES SHALL NOT BE SHARP AS TESTED PER UL1439 'Test for Sharpness of Edges on Equipment'
5. Refer to Appendix E about test method of warpage.

### *microSD package: Dimensions*